

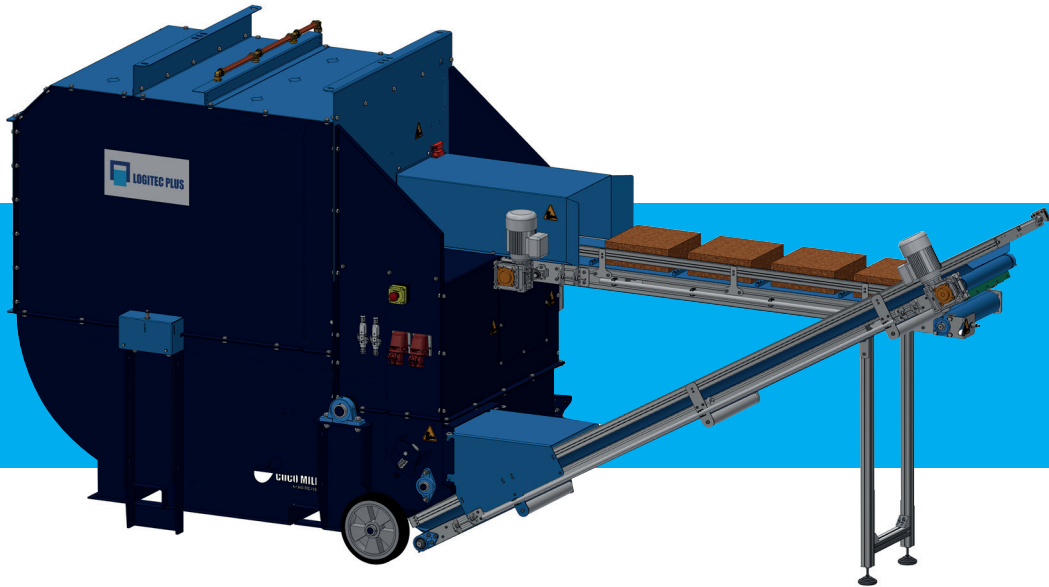

COCO MILL CM100



 Automatisch wellen van 5kg kokosblokken | Stof-arm | Waterbesparend | Geen verlies van volume & structuur | Verwerkt ca. 5-10m³ per uur.

 Automatic soaking of 5kg coir blocks | Low dust | Water saving | No loss of volume & structure | Processes approx. 5-10m³ per hour.

 Maceración automática de bloques de coco de 5 kg | Poco polvo | Ahorro de agua | Sin pérdida de volumen y estructura | Procesa aprox. 5-10m³ por hora.

OPTIES / OPTIONS / OPCIONES

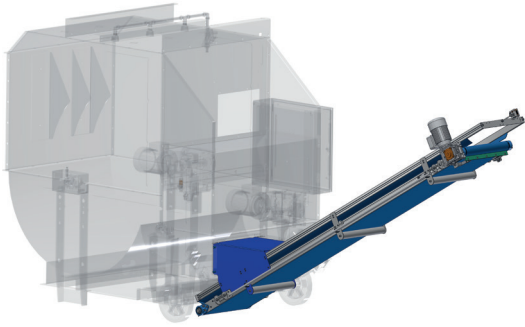

Uitvoerband 2900 mm lang
Outfeed belt 2900 mm long
Cinta de salida 2900 mm de largo

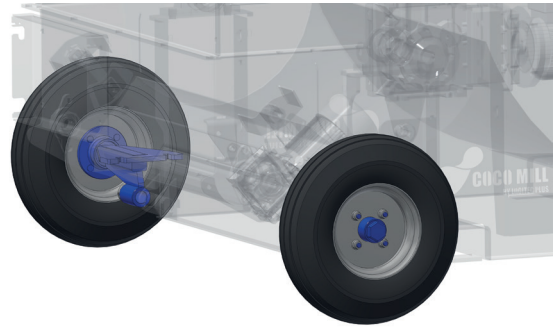

Grote rubberen wielen voor onverhard terrein
Large rubber wheels for unpaved terrain
Grandes ruedas de goma para uso todoterreno

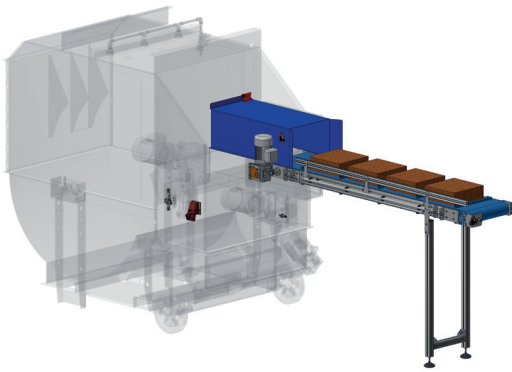

Semi-automatische invoerband
Semi- automatic Infeed belt
Transportador de alimentación semi-automático

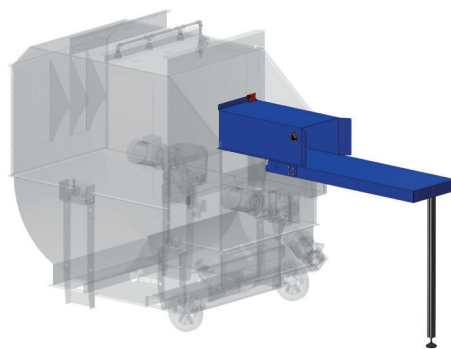

Handmatig invoerplateau
Manual infeed tray
Bandeja de alimentación manual

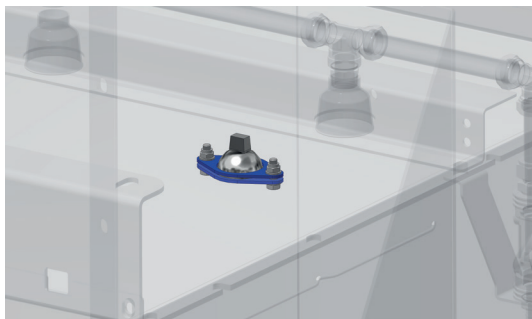

Ledverlichting
Led lighting
Iluminación led

SPECIFICATIES / SPECIFICATIONS/ ESPECIFICACIONES

	Merk:	Logitec Plus
	Model:	Coco Mill CM100
	Werkafmetingen*:	433 x 154,5 x 206,5 cm (LxBxH) <i>*inclusief in en uit-voerband</i>
	Transportafmetingen:	300 x 154,5 x 206,5 cm (LxBxH)
	Afmetingen kokos blokken:	30 x 30 x 10 cm (LxBxH)
	Doseer capaciteit:	Tussen de 5 en 10m ³ per uur
	Max laadgewicht:	10 - 12 blokken van 5 kg
	Gewicht van de machine:	1100 - 1400 kg
	Elektrische aandrijving:	Totaal 3,52KW (1 x 1,5KW + 1 x 1,1 KW + 1 x 0,55 KW + 1 x 0,37 KW) 400V/3 fasen/50HZ met optie invoerband totaal 3,89KW (+0,37KW). Andere spanningen beschikbaar op aanvraag.

	Brand:	Logitec Plus
	Model:	Coco Mill CM100
	Working dimensions*:	433 x 154,5 x 206,5 cm (LxWxH) <i>*including infeed and outfeed-belt</i>
	Transport dimensions:	300 x 154,5 x 206,5 cm (LxWxH)
	Size of coco blocks:	30 x 30 x 10 cm (LxWxH)
	Dosing capacity:	Between 5 and 10m ³ per hour
	Max Loading weight:	10 - 12 blocks of 5 kg
	Weight of the machine:	1100 - 1400 kg
	Electric power:	Total 3.52KW (1 x 1.5KW + 1 x 1.1 KW + 1 x 0.55 KW + 1 x 0.37 KW) 400V/3 phase/50HZ with option infeed belt total 3.89KW (+0.37KW). Other voltages available: 400V 3 phase 50Hz, 400V 3 phase 60Hz, 208V 3 phase 60Hz and 230V 3 phase 60Hz.

	Marca:	Logitec Plus
	Modelo:	Coco Mill CM100
	Dimensiones de trabajo*:	433 x 154,5 x 206,5 cm (LxAxA) <i>*incluido el transportador de entrada y salida</i>
	Dimensiones de transporte:	300 x 154,5 x 206,5 cm (LxAxA)
	Tamaño de los bloques de coco:	30 x 30 x 10 cm (LxAxA)
	Capacidad de dosificación:	Entre 5 y 10 m ³ por hora
	Peso máximo de carga:	10 - 12 bloques de 5 kg
	Peso de la máquina:	1100 - 1400 kg
	Potencia eléctrica:	Total 3,52KW (1 x 1,5KW + 1 x 1,1 KW + 1 x 0,55 KW + 1 x 0,37 KW) 400V/3 fase/50HZ con cinturón de entrada opcional total 3,89KW (+0,37KW). Otras tensiones disponibles bajo pedido.

DIMENSIES / DIMENSIONS / DIMENSIONES

met semi-automatische invoerband / with semi-automatic infeed belt
con cinta de alimentación semiautomática

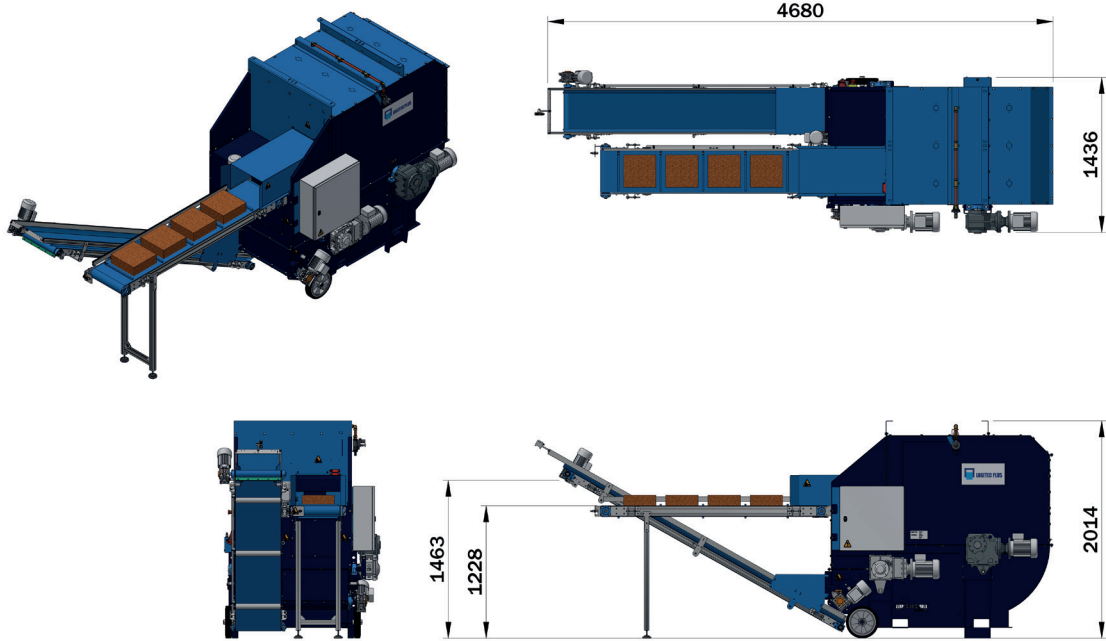

met handmatig invoerplateau / with manual infeed platform
con plataforma de alimentación manual

