

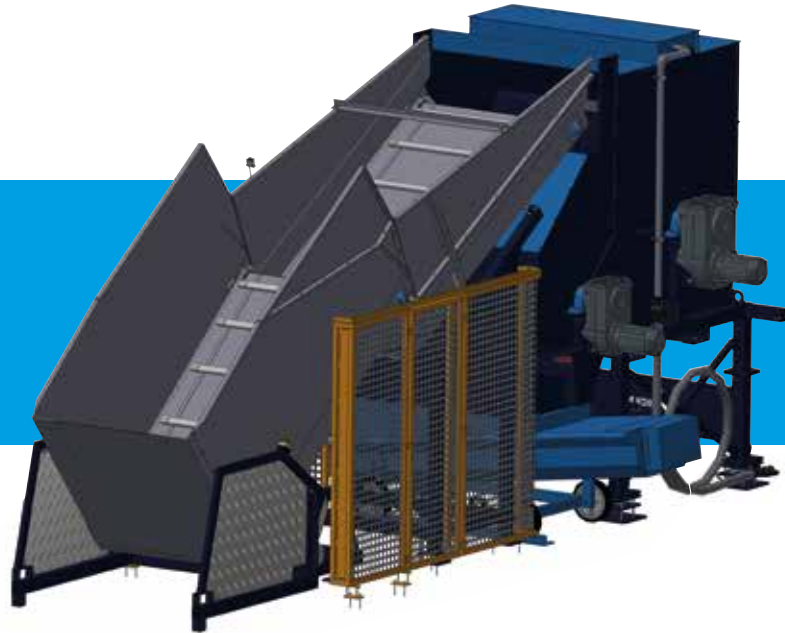



COCO MILL CM200



 Geen verlies van water en structuur | Geen stofvorming | Max. uitvoervolume | Automatisch vullen | Geen morsen van vuil water | Verwerkt tussen 13-22 m³ per uur | Geschikt voor het verwerken van 5kg blokken | Max. blokcompressie 8:1 | Geschikt voor fijne of grove kokossoorten.

 No loss of water and structure | No dust formation | Max output volume | Automatic filling | No spilling of dirty water | Processes between 13-22 m³ per hour | Suitable for processing 5kg blocks | Max block compression 8:1 | Suitable for fine or coarse types of coir.

 Sin pérdida de agua y estructura | Sin formación de polvo | Máximo volumen de salida | Llenado automático | Sin derrame de agua sucia | Procesa entre 13-22 m³ por hora | Adecuado para procesar bloques de 5kg | Máxima compresión de bloque 8:1 | Adecuado para tipos de coco finos o grueso.

SPECIFICATIES / SPECIFICATIONS/ ESPECIFICACIONES

met pallet invoer / with pallet infeed / con entrada para palets

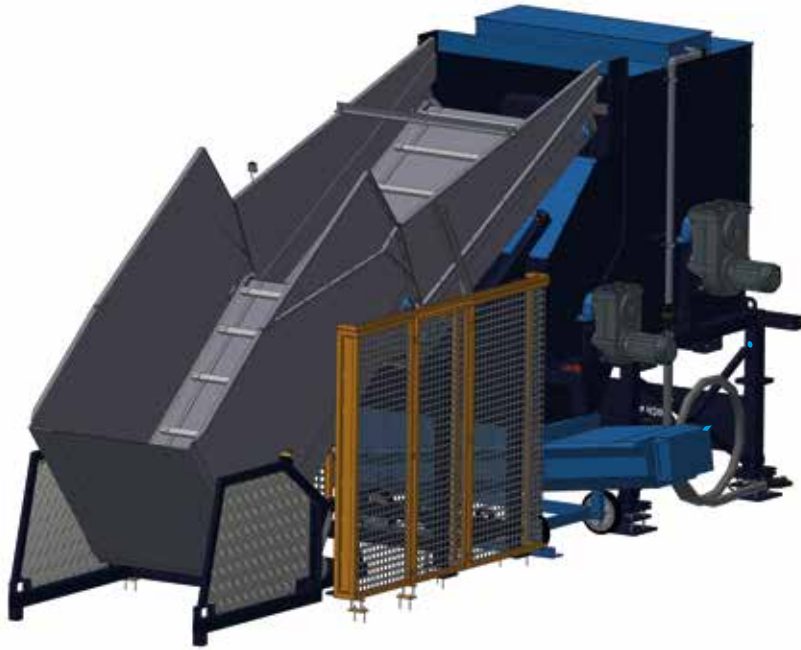

	Merk:	Logitec Plus
	Model:	Coco Mill CM200
	Dimensies:	689 x 272 x 328 cm (LxBxH)
	Verwerkingstijd:	13-22 m ³ per uur
	Max laadgewicht:	1 hele pallet met 5 kg blokken
	Gewicht machine:	5700 kg
	Elektrische aandrijving:	CM200 totaal 13,7KW (1 x 3 KW + 1x 3 KW + 1 x 2,2 KW + 2 x 2,2 KW + 1 x 1,1 KW) 400V/3 fasen/50HZ. Andere spanningen beschikbaar op aanvraag.

	Brand:	Logitec Plus
	Model:	Coco Mill CM200
	Dimensions:	689 x 272 x 328 cm (LxWxH)
	Processing time:	13-22 m ³ per hour
	Max loading weight:	1 whole pallet of 5 kg blocks
	Machine weight :	5700 kg
	Electric power:	CM200 total 13,7KW (1 x 3 KW + 1x 3 KW + 1 x 2,2 KW + 2 x 2,2 KW + 1 x 1,1 KW) 400V/3 phase/50HZ. Other voltages available on request.

	Marca:	Logitec Plus
	Modelo:	Molino de Coco CM200
	Dimensiones:	689 x 272 x 328 cm (LxAxA)
	Tiempo de procesamiento:	13-22 m ³ por hora
	Peso máximo de carga:	1 paleta entera con bloques de 5 kg
	Peso de la máquina:	5700 kg
	Potencia eléctrica:	CM200 total 13,7KW (1 x 3 KW + 1x 3 KW + 1 x 2,2 KW + 2 x 2,2 KW + 1 x 1,1 KW) 400V/3 fases/50HZ. Otras tensiones disponibles bajo pedido.

SPECIFICATIES / SPECIFICATIONS/ ESPECIFICACIONES

met bulk invoer / with bulk infeed / con entrada masiva

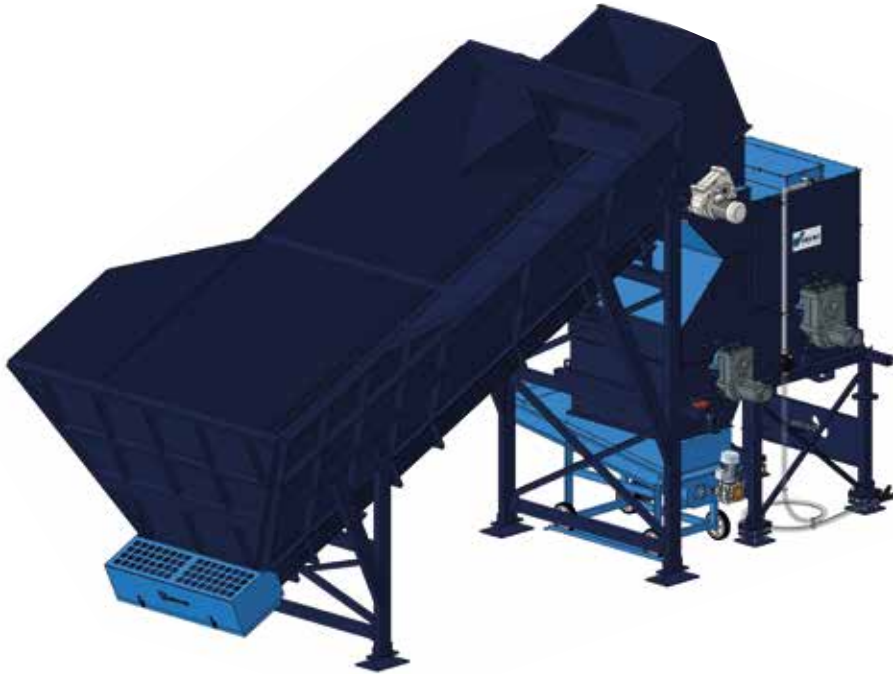

	Merk:	Logitec Plus
	Model:	Coco Mill CM200
	Dimensies:	939 x 391 x 528 cm (LxBxH)
	Verwerkingstijd:	13-22 m ³ per uur
	Max laadgewicht:	1-2 buckets van shovel
	Gewicht machine:	6500 kg
	Elektrische aandrijving:	CM200 totaal 17,7KW (1 x 3 KW + 1 x 3KW + 1 x 2,2 KW + 1x 4 KW + 1 x 5,5 KW) 400V/3 fasen/50HZ. Andere spanningen beschikbaar op aanvraag.

	Brand:	Logitec Plus
	Model:	Coco Mill CM200
	Dimensions:	939 x 391 x 528 cm (LxWxH)
	Processing time:	13-22 m ³ per hour
	Max loading weight:	1-2 buckets from front end loader
	Machine weight:	6500 kg
	Electric drive:	CM200 total 17,7KW (1 x 3 KW + 1 x 3KW + 1 x 2,2 KW + 1x 4 KW + 1 x 5,5 KW) 400V/3 phase/50HZ. Other voltages available on request.

	Marca:	Logitec Plus
	Modelo:	Molino de Coco CM200
	Dimensiones:	939 x 391 x 528 cm (LxAxA)
	Tiempo de procesamiento:	13-22 m ³ por hora
	Peso máximo de carga:	1-2 cucharones de cargador frontal
	Peso de la máquina:	6500 kg
	Accionamiento eléctrico:	CM200 total 17,7KW (1 x 3 KW + 1 x 3KW + 1 x 2,2 KW + 1x 4 KW + 1 x 5,5 KW) 400V/3 fases/50HZ. Otras tensiones disponibles bajo pedido.

DIMENSIES / DIMENSIONS / DIMENSIONES

met pallet invoer / with pallet infeed / con entrada para palets



met bulk invoer / with bulk infeed / con importación masiva

